

INSTALLATION

The RHT-P10 electronic housing is designed for wall mounting, while its remote sensor probe is intended for inserting and screwing in a flange.

Remove the housing front panel to access the two fixing holes, shown in Fig. 07.

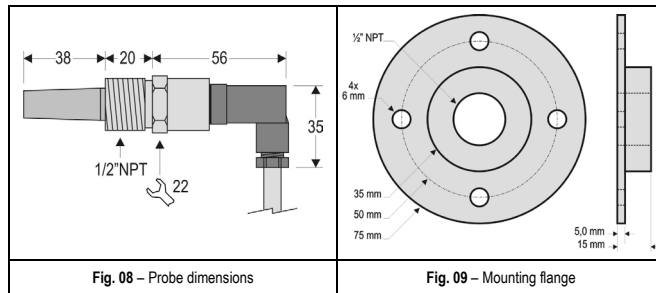
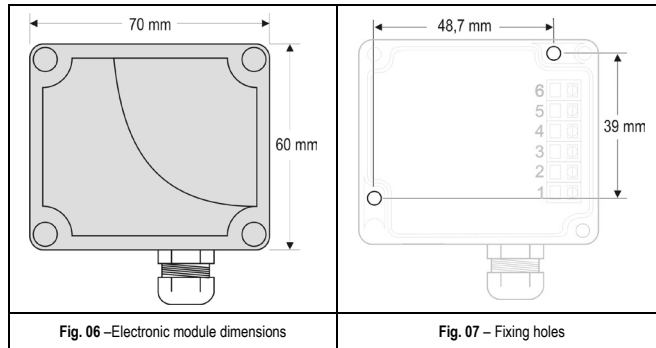

Note: The flange is not bundled with the transmitter. It must be ordered separately.

ELECTRICAL CONNECTIONS

The transmitter can be ordered as 4-20 mA current output or 0 to 10 Vdc voltage output. The output signal is defined on purchase and cannot be later changed.

Variables can be monitored together or separately. Combinations of mobile jumpers J4 and J5 within the transmitter case define how variables will be used. The jumpers also define the transmitter terminals with available output signals.

Jumper J5	Jumper J4	OUT1	OUT2
Position A	Position A	Temperature	Humidity
Position A	Position B	Temperature	Off
Position B	Position A	Humidity	Off
Position B	Position B	Humidity	Temperature

Table 01 - Configuration of OUT1 and OUT2 outputs

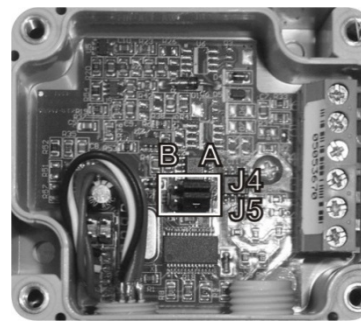
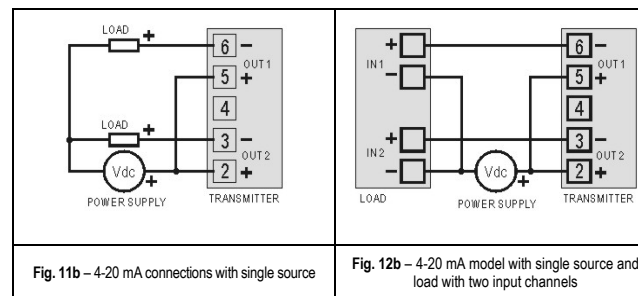
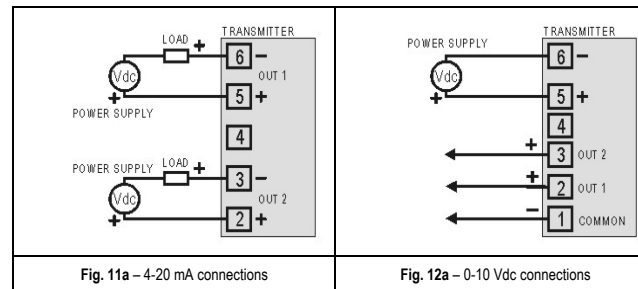

Fig. 10 - J4 and J5 position within the transmitter

Fig. 11 and 12 show the required electrical connections.

⚠ Check that loop OUT1 must always be powered in 4-20 mA model!



LOAD represents the output signal measurement equipment (controller, register, etc).

The connection wires go inside the transmitter trough to the cable gland mounted in the transmitter case.

INSTALLATION RECOMMENDATIONS

- Conductors of small electrical signals must be distant from activation or high-tension/current conductors, preferably passing through grounded conduits.
- A specific electrical power supply network should be provided for instruments use only.
- In controlling and monitoring applications, possible consequences of any system failure must be considered in advance.
- RC filters (47 R and 100 nF, serial) in inductor charges (contactors, solenoids, etc.) are recommended.

HUMIDITY AND TEMPERATURE TRANSMITTER

RHT-P10

OPERATING MANUAL

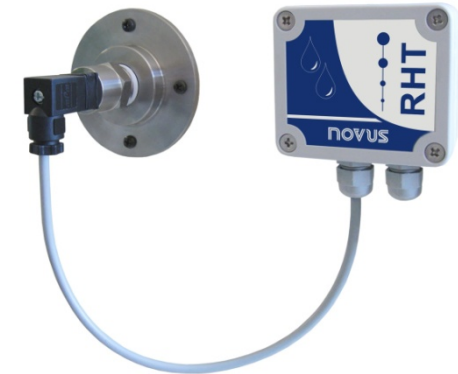

NOVUS
We Measure, We Control, We Record

Man 5000224 V1.2x G

ATTENTION

The calibration of the humidity sensor may change in case it is exposed to contaminating vapors or to high humidity and temperature conditions for extended periods. In order to speed up the calibration restoration, proceed as described below:

- Remove the sensor from the capsule.
- Wash it with water in case there are solid particles on it.
- Place it within a 80 °C (+-10 °C) oven for 24 hours.
- Place it for 48 hours in a place with a temperature between 20 and 30 °C and humidity over 75 % RH.
- Place the sensor back in the capsule.

WARRANTY

Warranty conditions are available on our website www.novusautomation.com.

SPECIFICATIONS

Humidity measurement:

Total accuracy: Refer to Fig. 01;

Measuring range: Configurable between 0 and 100 % RH or -100 and 103 °C for dew point;

Response Time (1/ e (63 %)): 4 seconds @ 25 °C (in slow moving air 1 m/s);

Temperature measurement:

Total accuracy: Refer to Fig. 01;

Measuring range: Configurable between -40 and 120 °C;

Response time (1/ e (63 %)): up to 30 seconds (in slow moving air 1 m/s);

General specifications:

Power supply: 4-20 mA model: 12 Vdc to 30 Vdc
0-10 V model: 18 to 30 Vdc / 15 mA max.

Outputs: 4-20 mA or 20-4 mA current, 2-wire – loop power supply;
0-10 Vdc / 2 mA máx. (0-10 V model)

Output Load (RL): 4-20 mA output: $RL \text{ (Ohms max.)} = (Vdc - 12) / 0.02$
Where: Vdc= Loop voltage supply (in Volts)
0-10 Vdc model: 2 mA max.

OUT1 output resolution: 0.006 mA (4-20 mA) / 0.003 V (0-10 V);

OUT2 output resolution: 0.022 mA (4-20 mA) / 0.015 V (0-10 V);

Isolation between loops: the 4-20 outputs are isolated from each other.
the 0-10 V are **not** isolated from each other.

Provides protection against power supply polarity inversion.

Operating limits: Electronic circuit: -10 to +65 °C, 0 to 95 % RH.
Sensor: See Fig. 01.

Max. pressure allowed in the probe: 10 Bar (145 PSI)

Protection standard: Electronic circuit case: IP65; Sensors capsule: IP40

Cable entrance: Compress fitting PG7

Process connection: stainless steel 304, ½" NPT thread (others upon request).

Cable length: 3 m (other lengths available upon request).

Sensor protected by sintered bronze capsule.

(*) Although the transmitter can be configured with a measuring range from -40 up to +120 °C, the sensor module must not be submitted to temperatures out of the -10 to +65 °C range.

IMPORTANT NOTE

The transmitter sensor may be damaged or lose calibration if it is exposed to aggressive atmospheres with high concentrations as Chloride Acid, Nitride Acid, Sulphuric Acid and Ammonia. Acetone, Ethanol and Propylene Glycol may cause reversible measurement errors.

Measures accuracy and sensor operating limits:

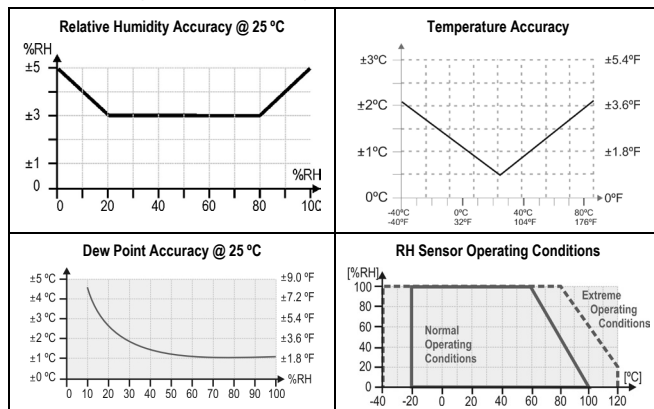

Fig. 01- RH and Temperature accuracies

CONFIGURATION

If the default configuration or the ordered configuration satisfies the application, then no further configuration is necessary and the transmitter is ready to be used. If a new setting is desired, this can be accomplished by the TxConfig and sent to the transmitter through the TxConfig interface.

The TxConfig Interface and Software compose the **Transmitter Configuration Kit**, with can be purchased separately from the manufacturer or one of its distributors. The latest release of this software can be downloaded from our web site. To install, run the Tx_setup.exe and follow the instructions.

The TxConfig interface connects the transmitter to the PC, as shown in Fig. 02 and 03. There are two types of interface: TxConfig-RS232 and TxConfig-USB.

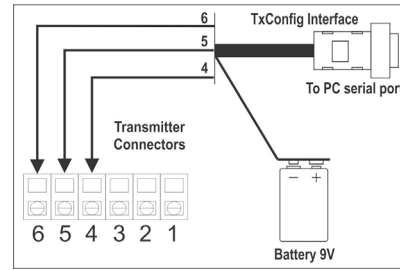

Fig. 02 – TxConfig Interface connections model RS232.

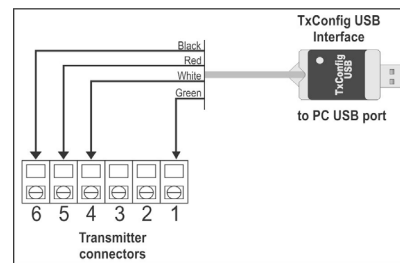

Fig. 03 – TxConfig Interface USB connections

Once the connection is accomplished, the software shows the configuration options of the transmitter model attached. Access the *Help* for usage instructions.

Fig. 04 shows the TxConfig software main screen.

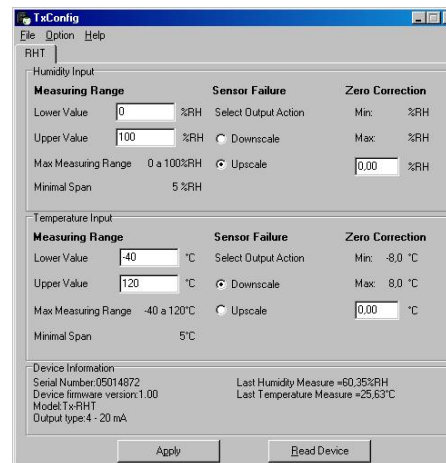

Fig. 04 – TxConfig software main window

The fields in the screen mean:

1. **Measuring Range:** Defines the output scale for the input sensor. Program here the measurement **Lower Range Value** and the **Upper Range Value**.

The values configured in these fields cannot be beyond the **sensor measuring range**. The **minimal span** value has to be observed as well.

When the lower limit is defined with a value higher than the Higher Limit the output current operates from 20 to 4 mA.

2. **Sensor Failure:** establishes the transmitter output behavior (upscale or down-scale) in the presence of a sensor fail. When Minimum is selected, the output current is < 4 mA (down-scale), typically used for refrigeration. When Maximum is selected, the output current is > mA (up-scale), typically used in heating systems.

3. **Zero Correction:** Allows for small sensor corrections.

4. **Device Information:** Transmitter identification data. These information must be informed when the user contact us.

5. **Read Device:** Brings to the screen the current transmitter parameters configuration.

6. **Apply:** Sends a new configuration to the transmitter.

Note: The factory default configuration is (unless otherwise specified or ordered):

- RHT sensor, temperature span 0 to 100 °C and humidity span 0 to 100 % RH;
- 0 °C of zero correction.
- Upscale when sensor fails.

It is important to notice that the transmitter accuracy is always based on the total span of the used sensor, even if a narrower range is configured. Example:

Humidity sensor has a total span of 0 to 100 % and accuracy of 3 % at 25 °C, as showed in Fig. 01. This 3 % RH error is the same no matter if the total span is configured (0 to 100%) or a narrower span (like 20 to 80 %).

During configuration, the transmitter needs to be electrically powered. TxConfig-USB interface can provide the power to the transmitter, but this also depends on the used computer hardware.

The TxConfig-RS232 interface, however, requires an auxiliary supply for guarantee reliable communication with the computer. An external 9 V battery can be used for this purpose (Fig. 02). An alternative is to configure the transmitter while it is in operation; this way, the needed energy is supplied by the current loop. See Fig. 05.

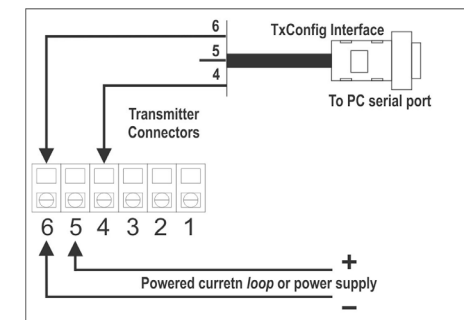
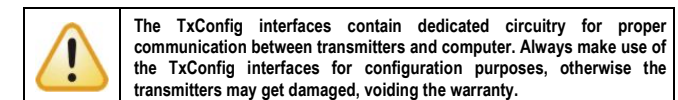

Fig. 05 – TxConfig Interface connections – Loop powered



Serial port configuration errors may occur when other software are sharing the same serial port. Close all serial port applications prior to using the TxConfig software.